

Compact Stepper Drive DSM9- SD

- Compact size
- Step and Direction input signals required
- Supply voltage 24 - 80V_{DC} , motor current 6,4 A_{rms}
- Microstep Resolutions up to 25.600 Steps per Revolution
- Idle current reduction
- Noiseless at standstill, smooth operation
- Low heat losses
- Chopper frequency 20kHz

Contact:
Danaher Motion GmbH
Robert-Bosch-Strasse 10
D-64331 Weiterstadt
Telefon: +49(0)6151-8796-10
Fax: +49(0)6151-8796-123
E-Mail: sales.germany@danahermotion.com
www.danahermotion.com



*Helping you build a better machine, **faster.***

The DSM9-SD drives are compact microstep power modules for 2-phase stepper motors with various configurations for the best possible customization to the individual application.

The most important attributes are:

- **Bipolar power stage**
- **Microstepping Ability**
- **Idle current reduction**

The units are designed for panel mounting and equipped with the mating plugs; the compact size allows installation, where only restricted mounting space is available. The customer's mounting panel partly serves as heat sink. The drive may contact the panel with its back or with its side. Those alternative methods increase installation flexibility.

Microstepping assures smooth operation and optimized system resolution. With 1,8° motors, a microstep resolution up to 25600 steps per revolution can be selected.

A 4-phase 20 kHz chopping PWM power stage electronically controls the motor winding currents. This combines the best of recirculating and non-recirculating current regulation to provide high back EMF rejection with low ripple current. Further benefits are reduced heat dissipation, low electrical noise and improved current control.

The idle current reduction permits an automatic 50% reduction of motor current to minimize heating during inactive periods. If no step signals are received for 0,1 sec (0,05 sec or 1 sec, adjustable) the current is automatically reduced. Current is reset to full amplitude upon incoming new step signals.

14 different step resolutions can be chosen.

Technical Data

Power Supply Voltage	nominal 70V _{DC} , power supply voltage range 24 to 80 V _{DC} For the power supply, only an unregulated DC voltage is required.
Motor Current	max. 9- A _{peak} ; 0,3 bis 6,4 A _{rms} Adjustable by a dip-switches. For 2-phase stepper motors with 4, 6, or 8 leads.
Input Interface	Step and direction, 5 V- or 24V-level
Idle Current Reduction	50 % (if selected)
Step Resolution	Adjustable up to 25.600 steps
Max. Input Frequency	500kHz
Inputs	Enable, Step and Direction
Outputs	Enabled / Status LEDs: Green: Drive enabled (no step signals); Yellow: Motor runs; Red: Error/Fault
Ambient Temperature /	0-50°C
Motor Current	Without heat sink: max 2,5A @ 25°C / 1,25 A @ 45° C With heat sink (optional): max 6,5A @ 25°C / 3,25 A @ 45° C
Chassis Temperature	max. 60°C, forced ventilation might be required
Humidity	10-90%, not condensing
Connectors	Power Supply: 4-pole plug-in screw terminal Motor: 5-pole plug-in screw terminal Logic: 9-pole Sub-D-socket

Step Size Resolution

Partition		Steps/Resolution (1,8°-Motor)	
decimal	decimal	decimal	binär
full stop	half step	200	400
half step	1/4	400	800
1/5	1/8	1.000	1600
1/10	1/16	2.000	3200
1/25	1/32	5.000	6400
1/50	1/64	10.000	12800
1/125	1/128	25.000	25600
1/2,5	1/5	500	1000

Dimensions:

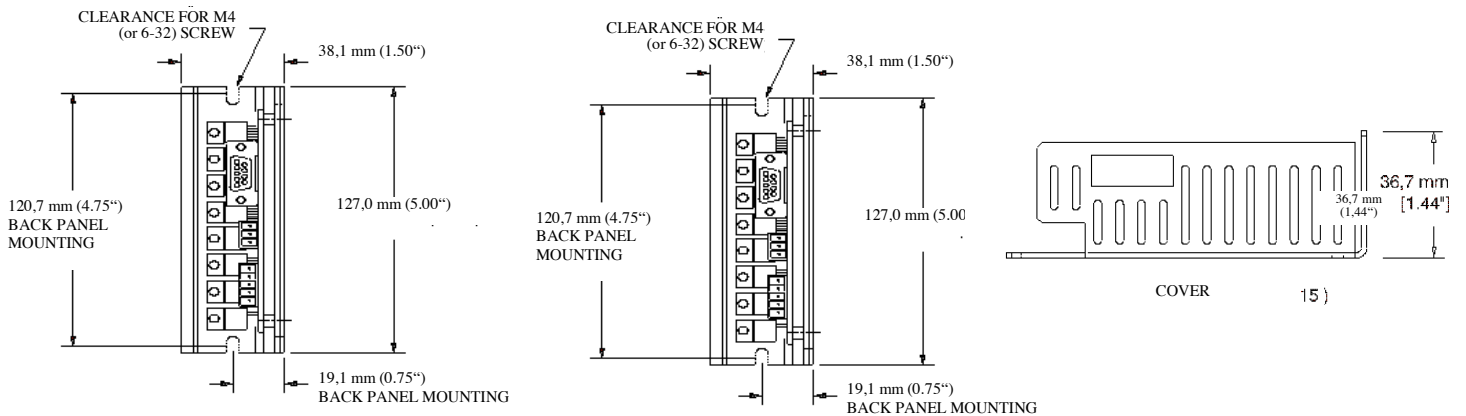

Order Code

- DSM9-SD-01 (Step and Direction inputs designed for 24 V-level)
- DSM9-SD-03 (Step and Direction inputs designed for 5 V-level)